

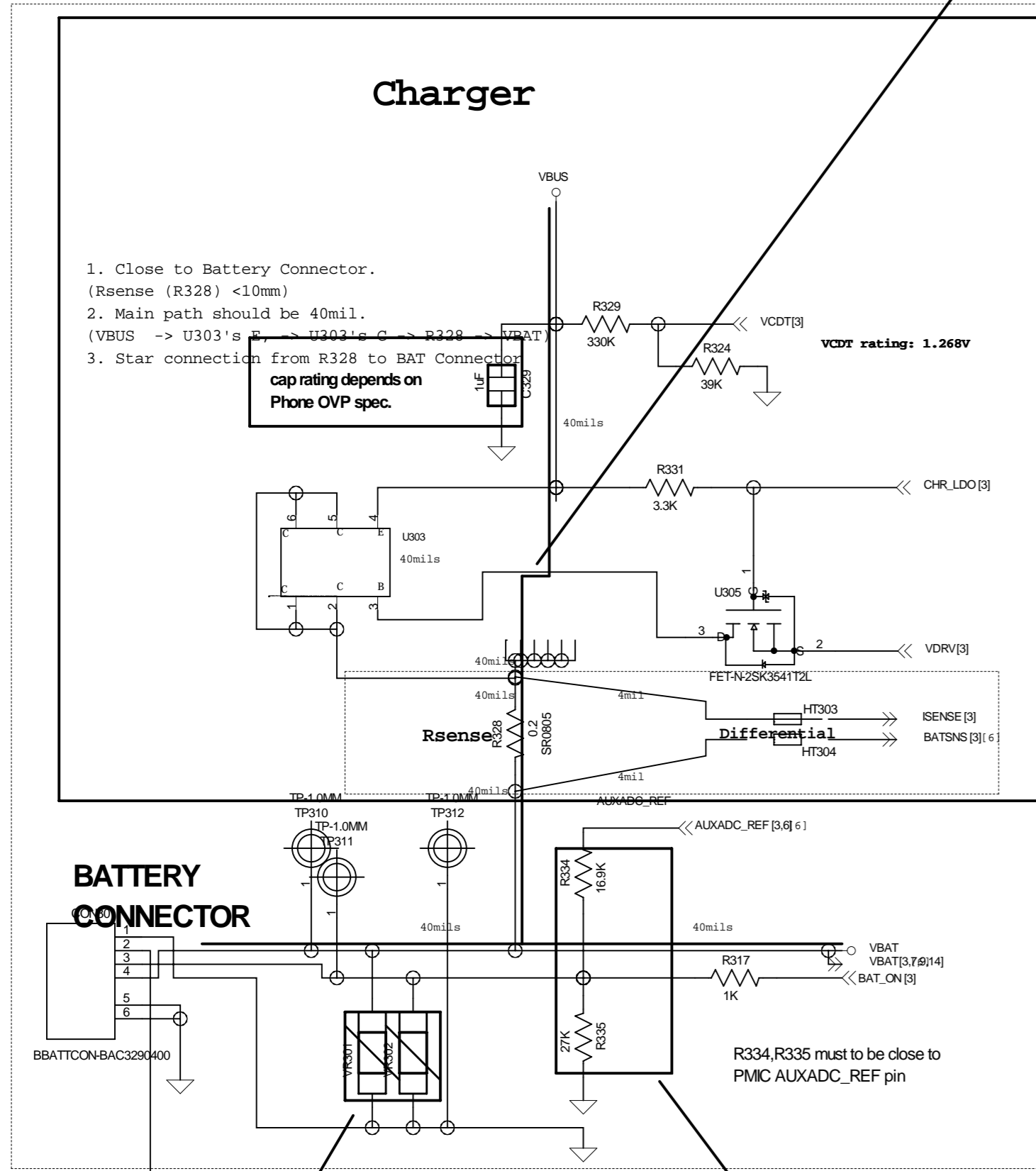

Before you select BJT , please take power dissipation into consideration.  
Refer to MT6323 design notice



Based on your system level design, if better ESD performance is needed on your system, please refer to ESD performance enhance proposal

if battery NTC is 10kohm, R334-16.9K, R335-27K  
if battery NTC is 47kohm, R334-61.9K, R335-100K

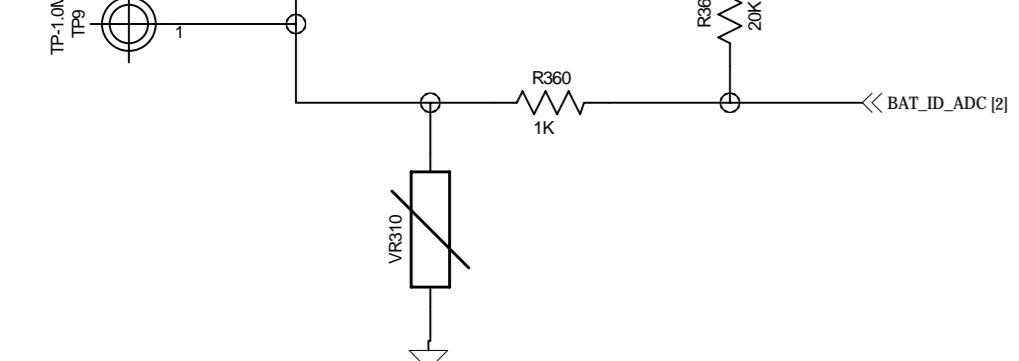

Refer to MT6323 design notice for Zener selection

Based on your system level design, if better EOS performance is needed on your system, please refer to EOS performance enhance proposal

Refer to MT6323 design notice for Buck GND layout rule

Refer to GPS co-clock layout rule

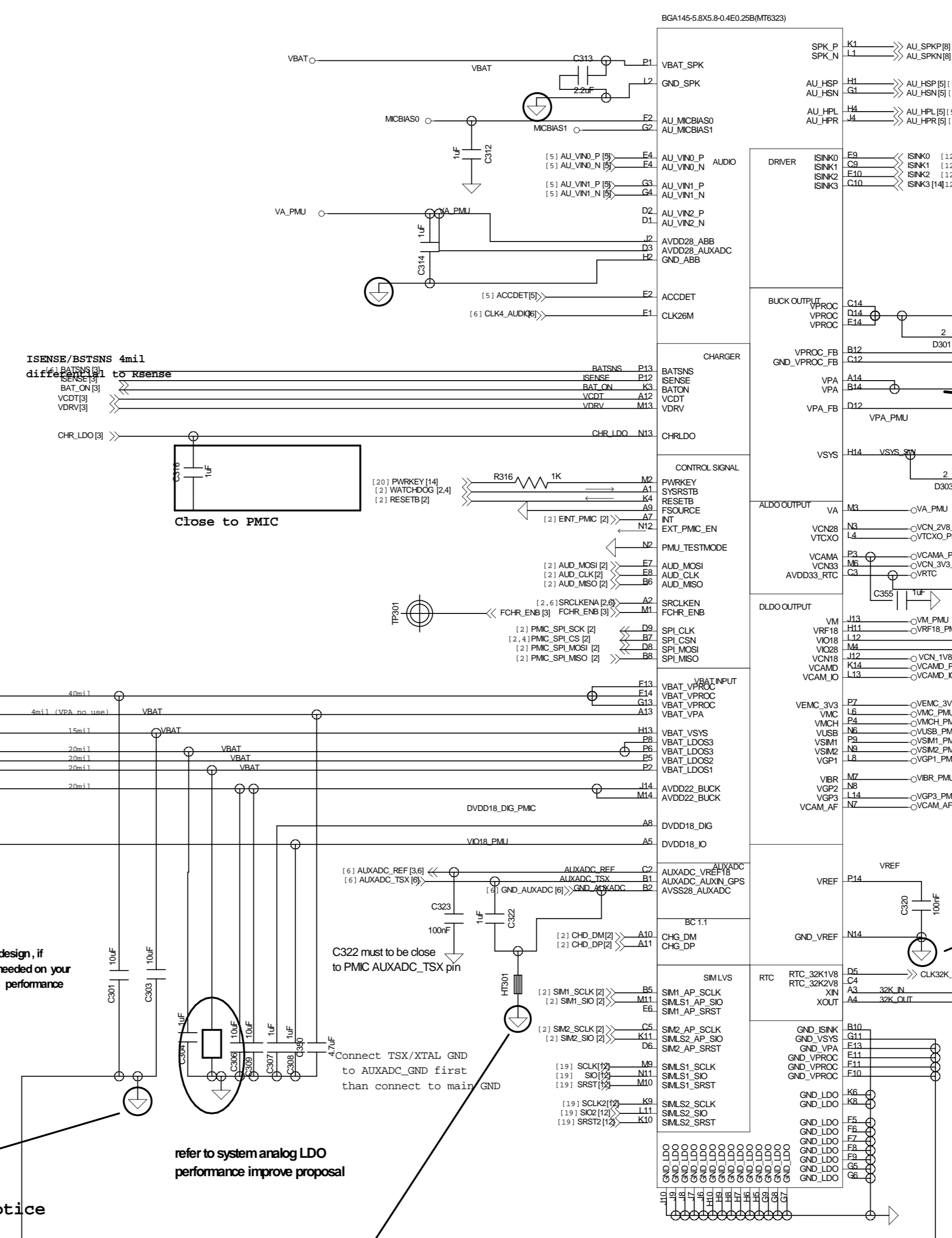

Please use inductor recommend by MTK Refer to MT6323 design notice

dedicate VSS ball, must return to cap then to main GND: GND\_VREF(N14) - C320

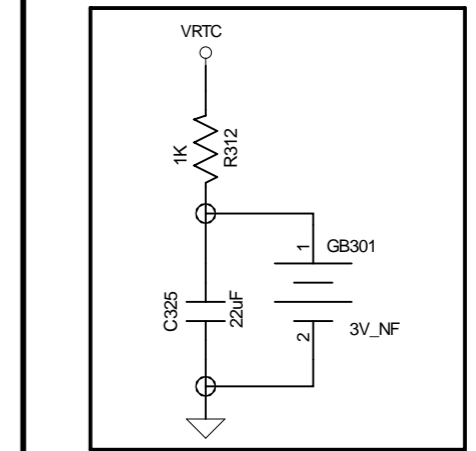
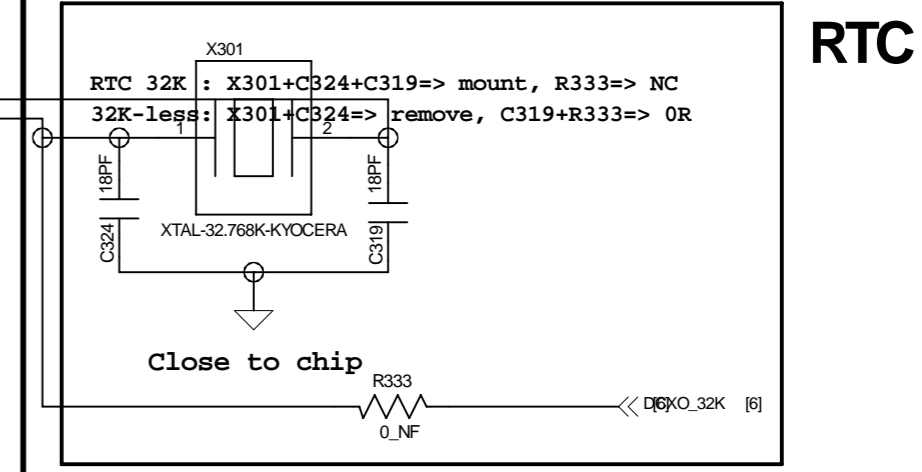

=> for longer RTC time sustain after battery remove, please refer to RTC design notice

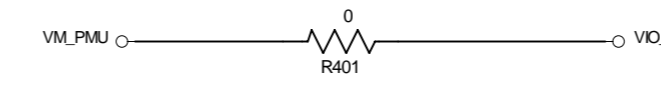

Memory MCP

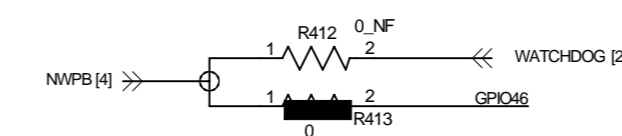
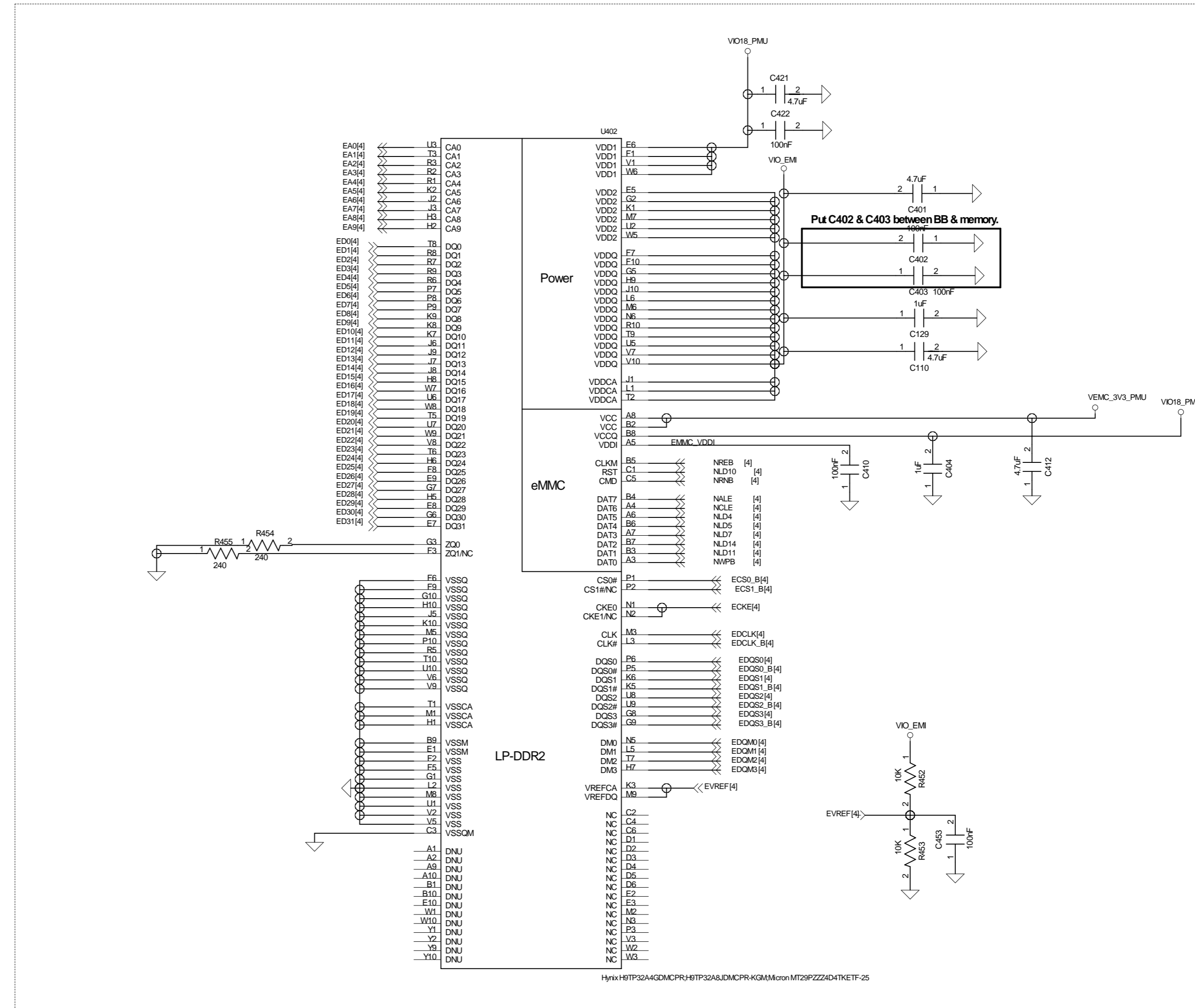
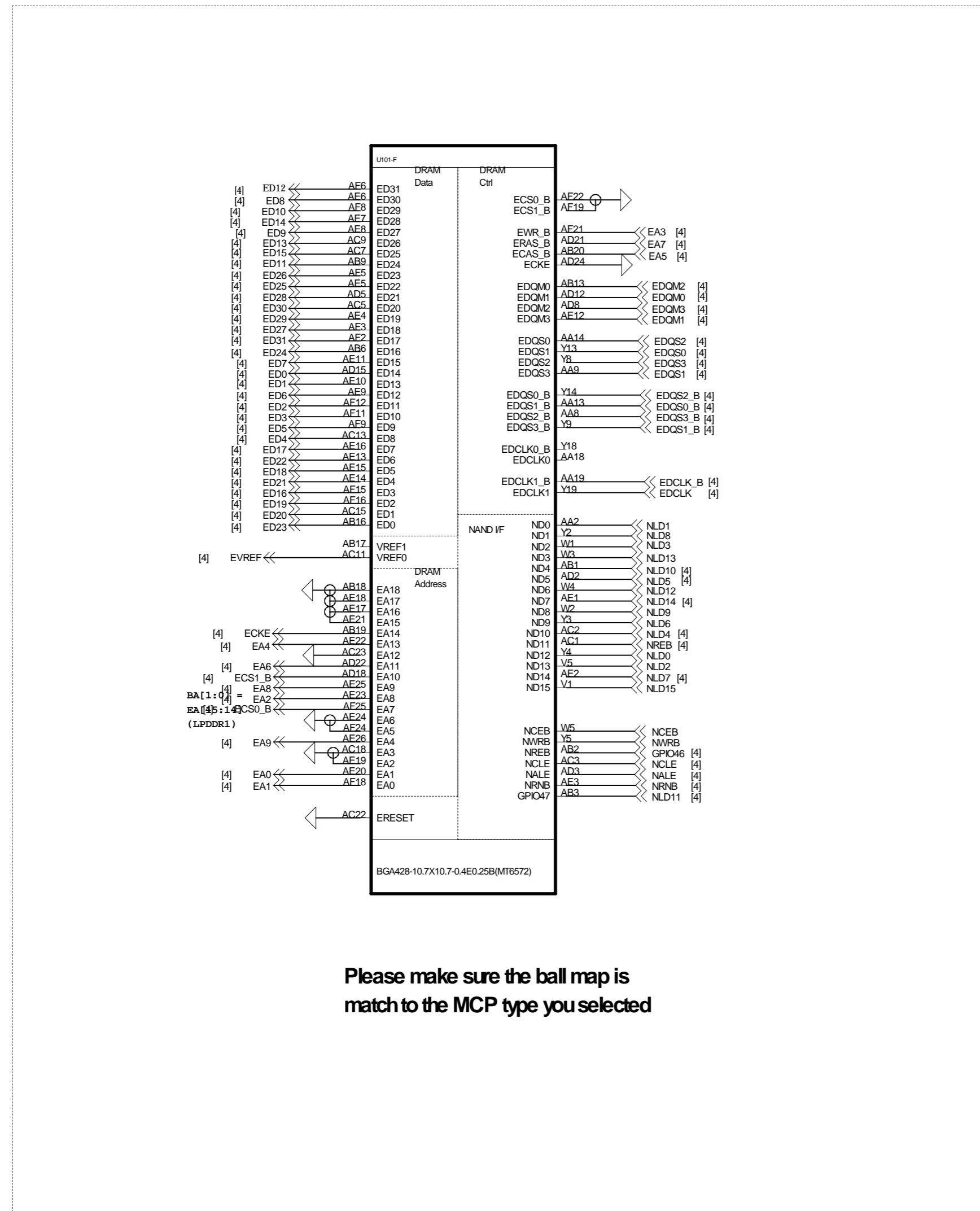

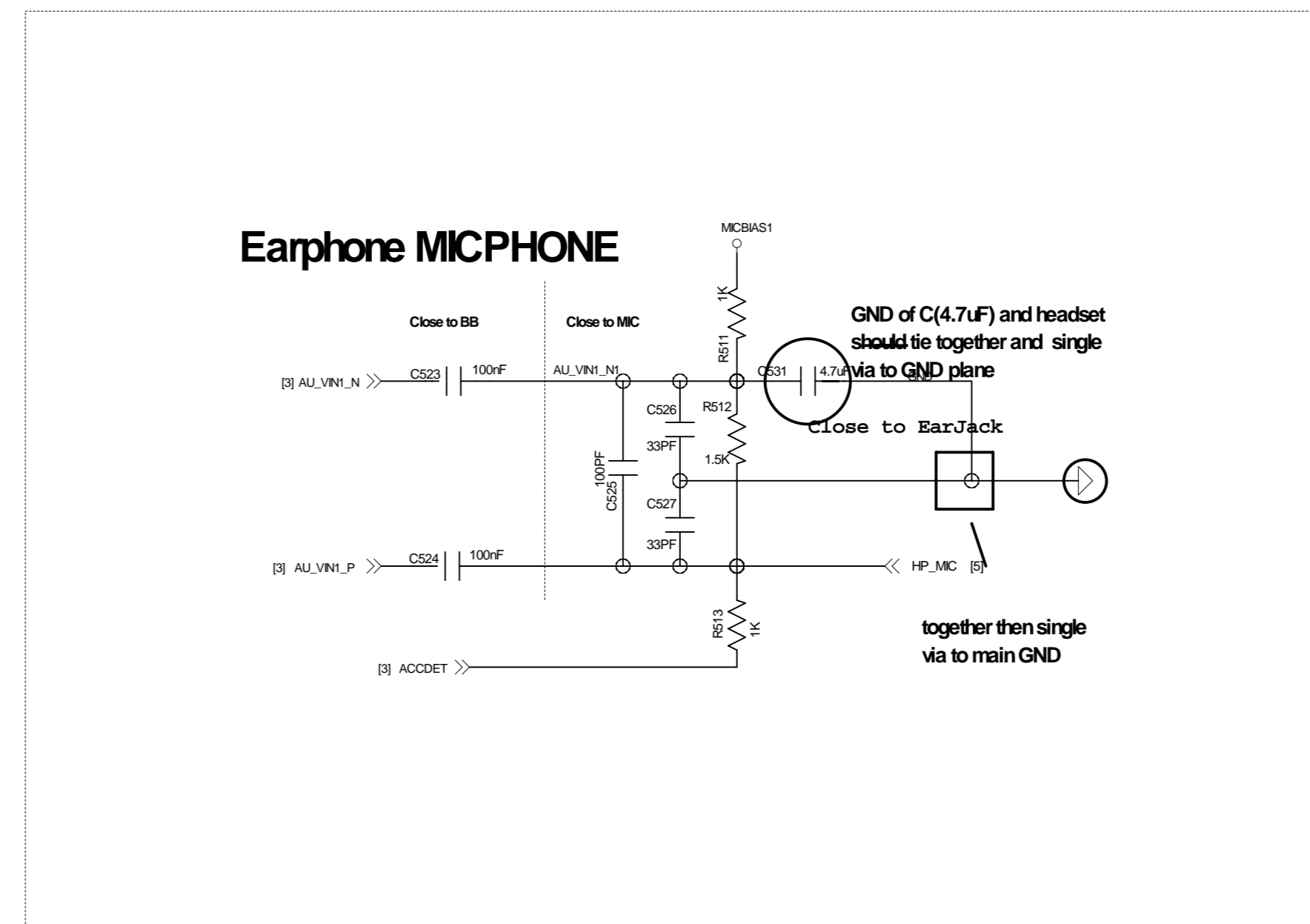
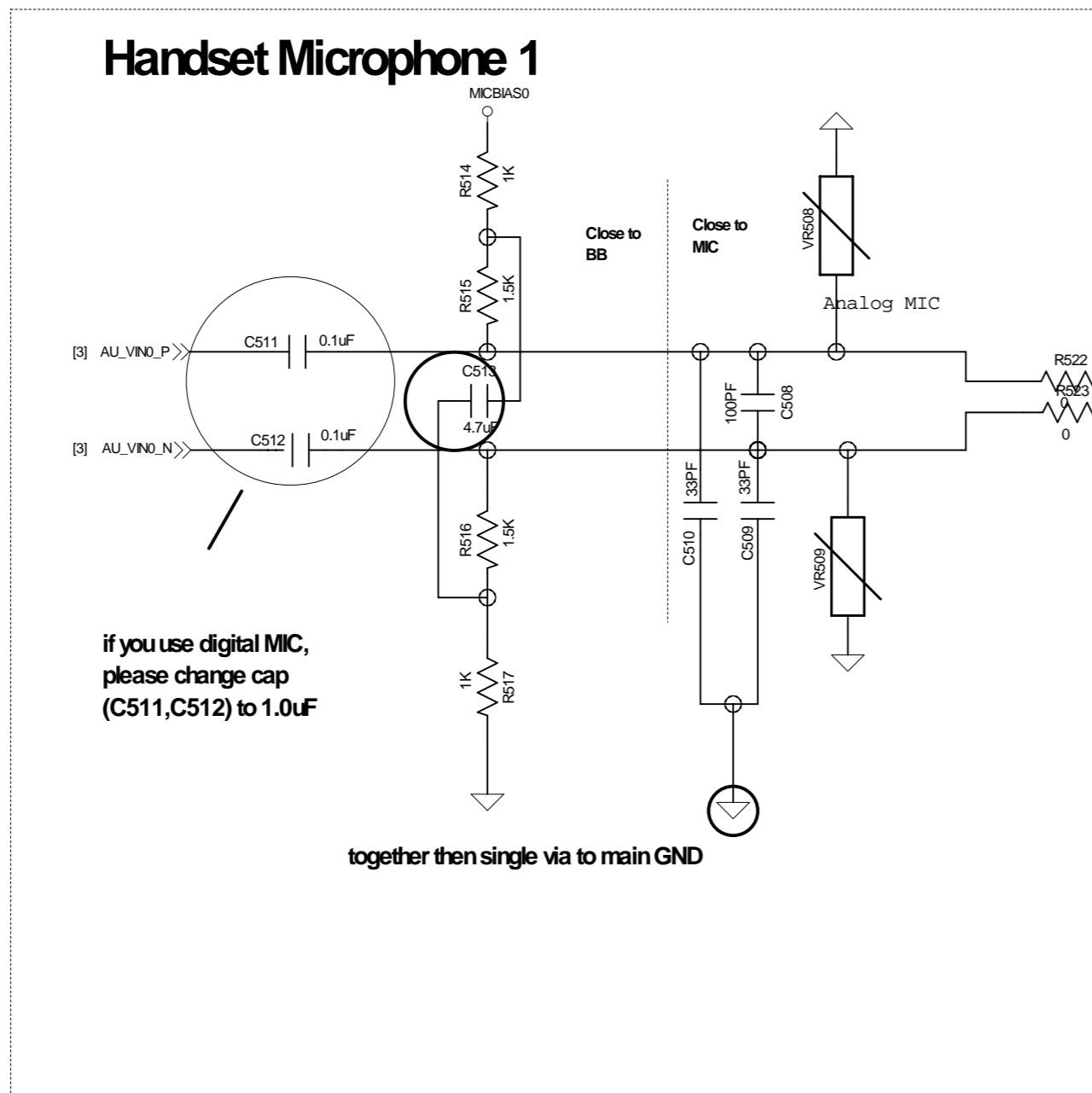
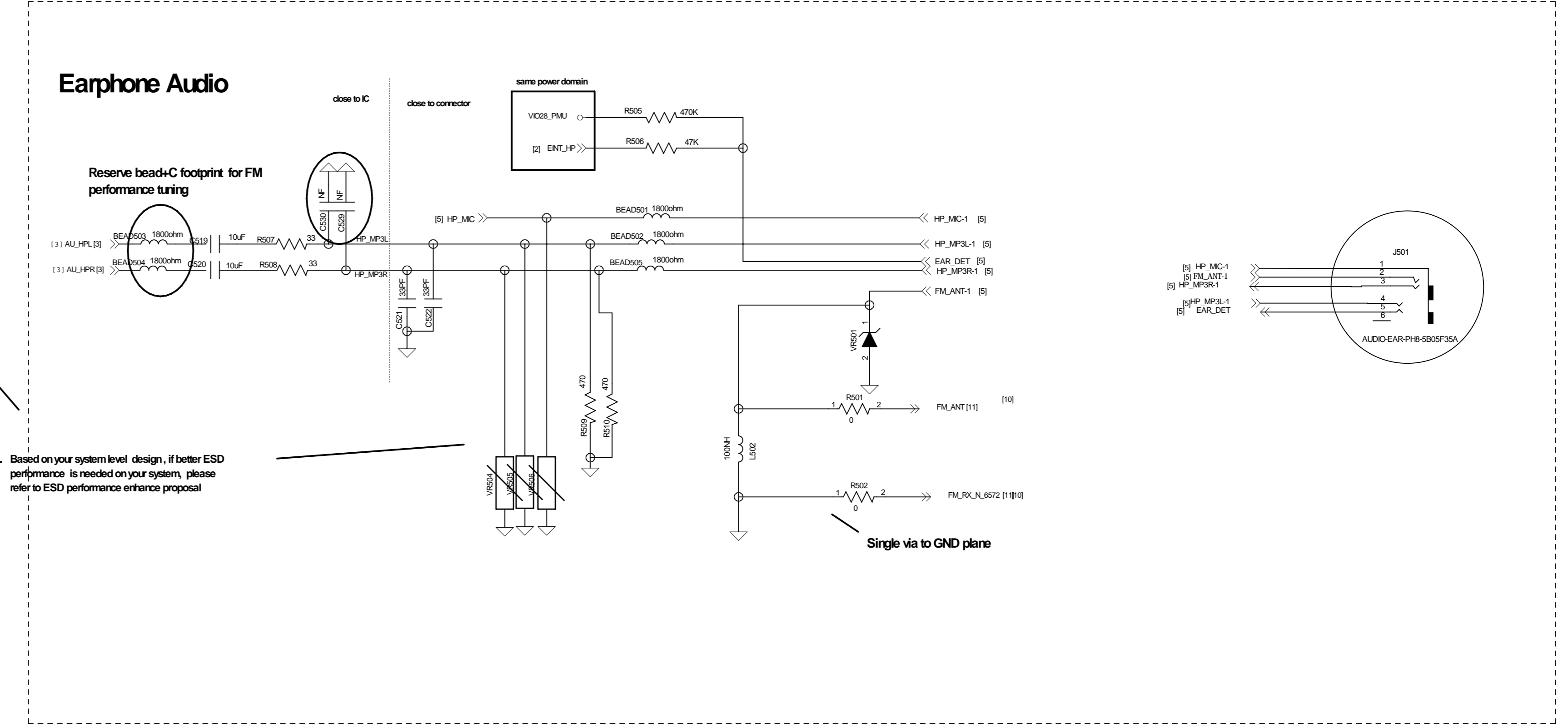
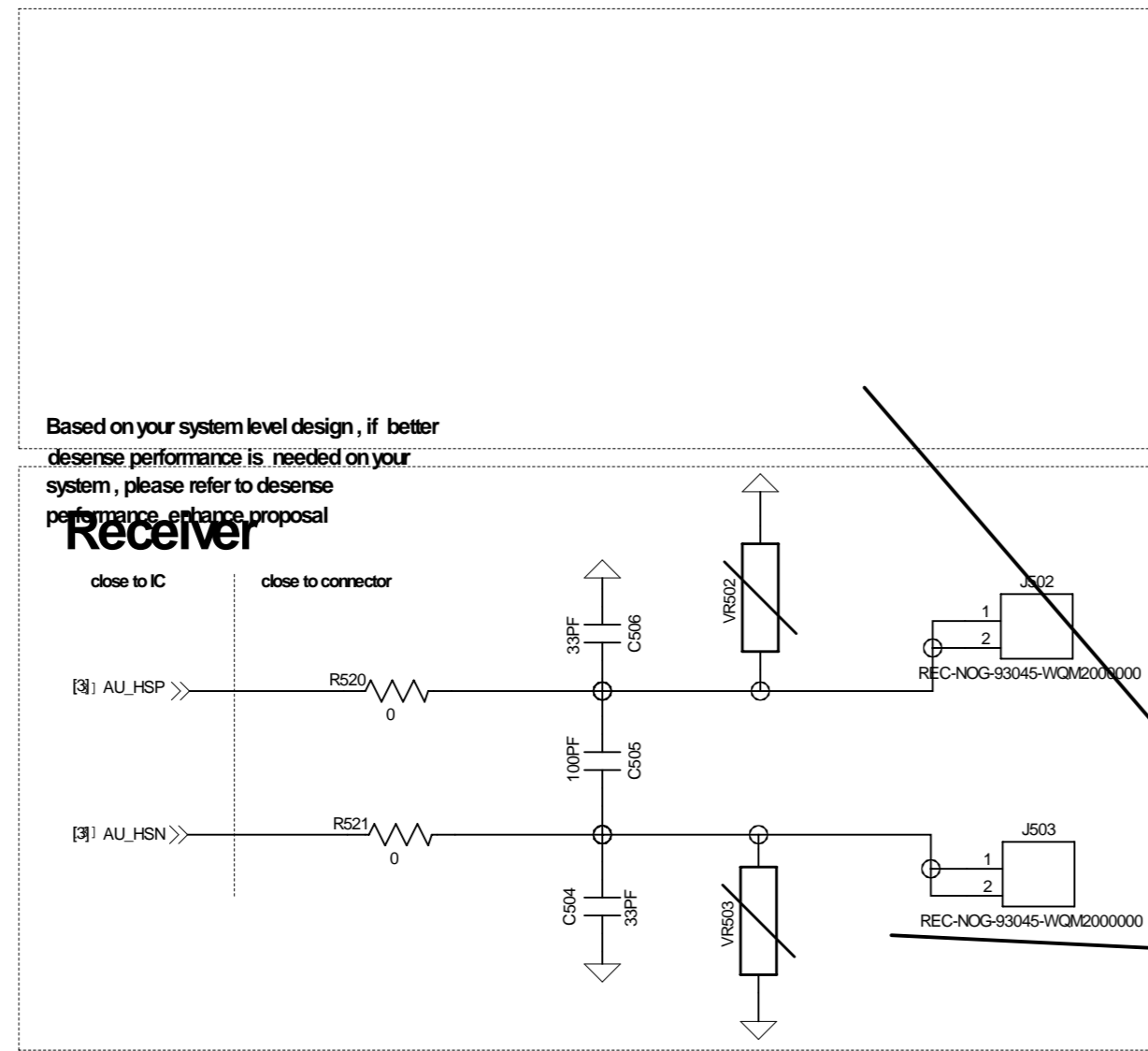

TITLE:	<TITLE>	REV:	<REV>
DOCUMENT NO:	04_MEMORY_EMMC_LPDDR2	SKED:	A1
DEPARTMENT:	Hardware DEPT.		
COMPANY:			
DESIGNER:	<DESIGNER>	Last Saved Date:	2013-6-26
		SHEET:	4 OF 15



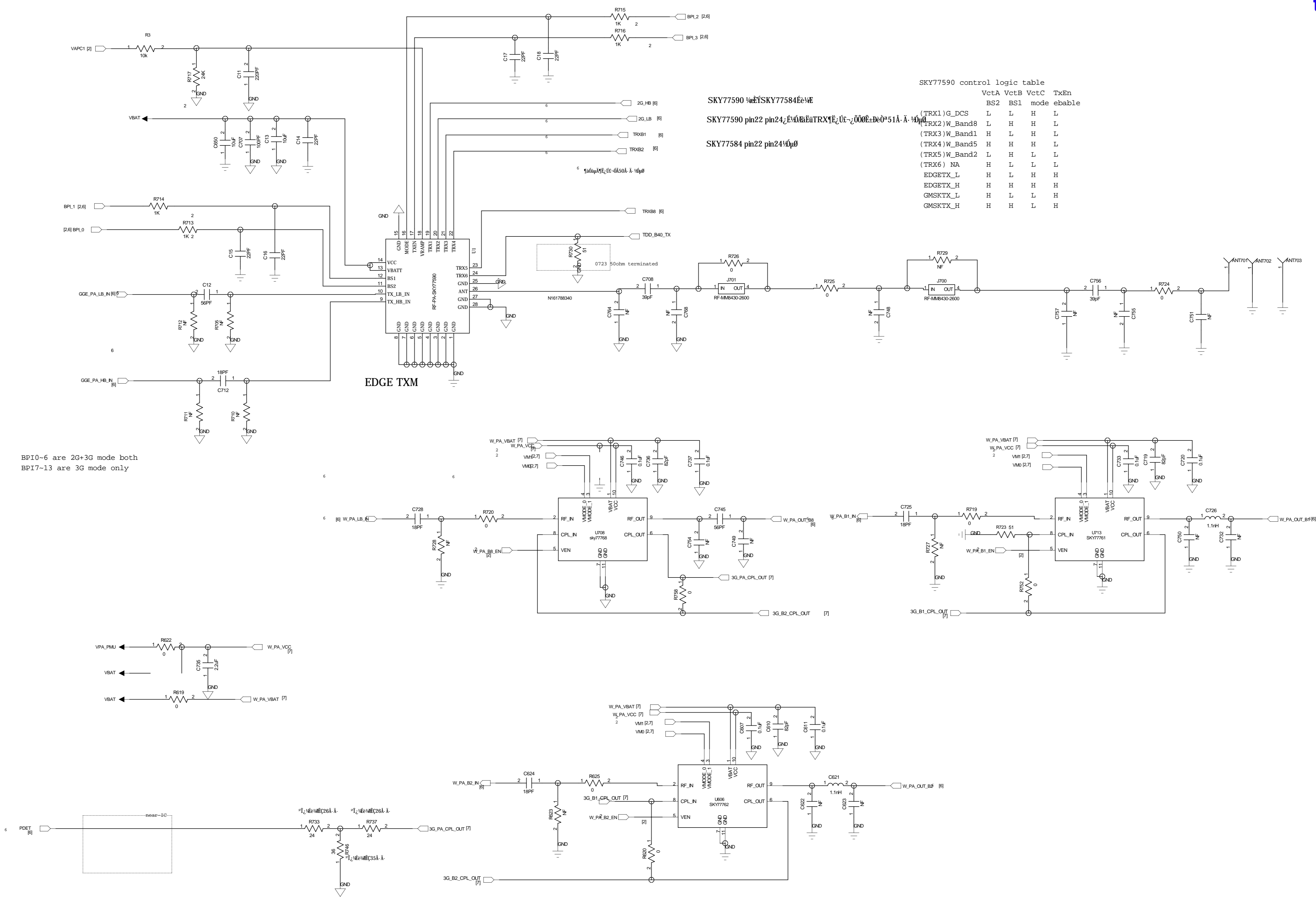

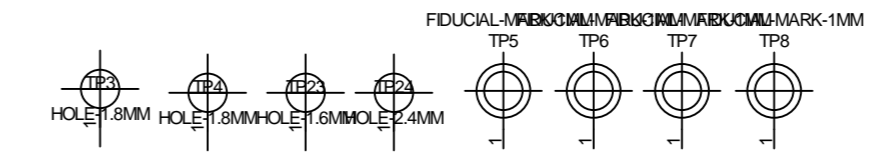
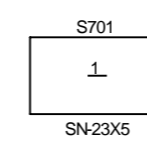
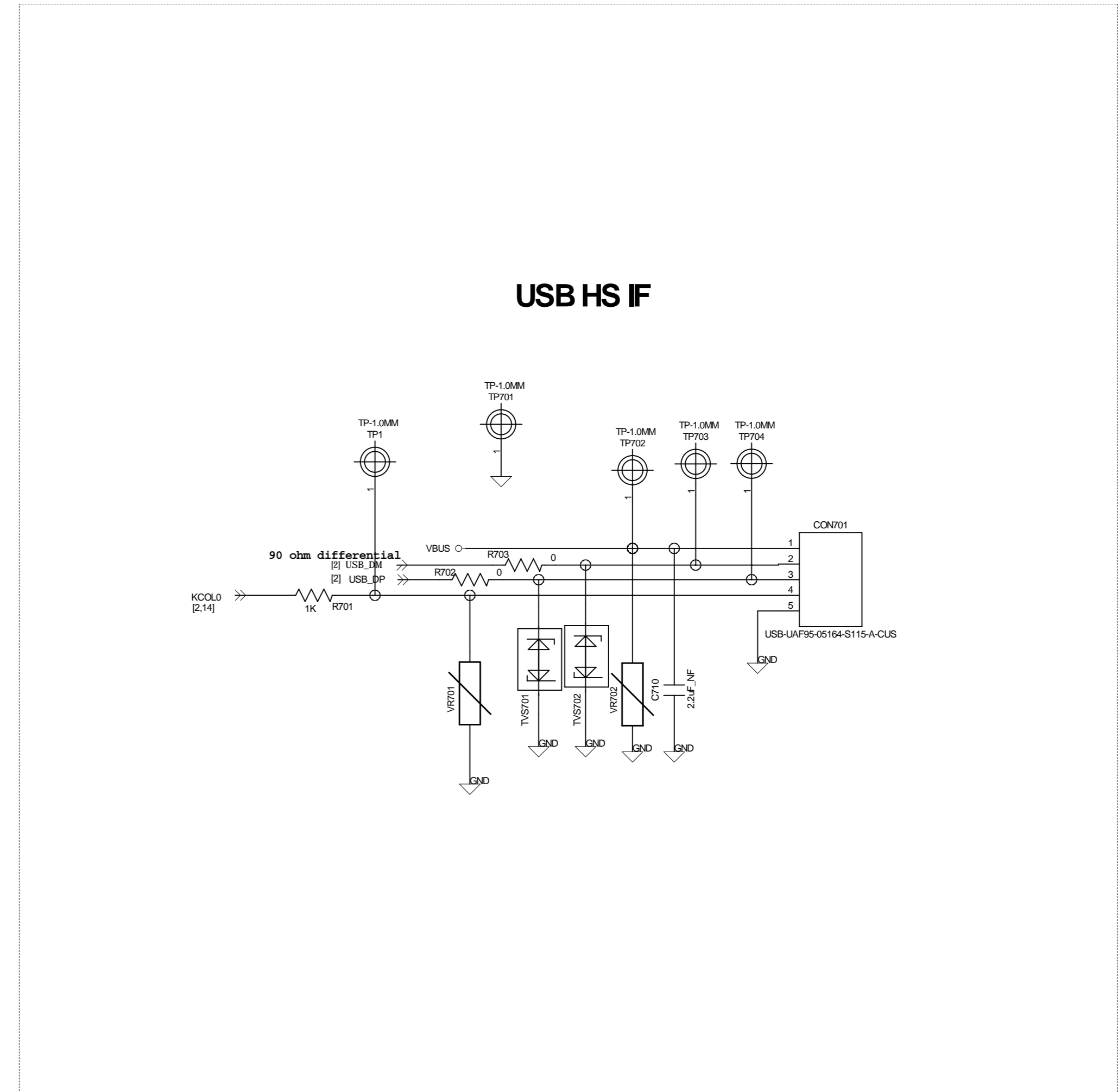
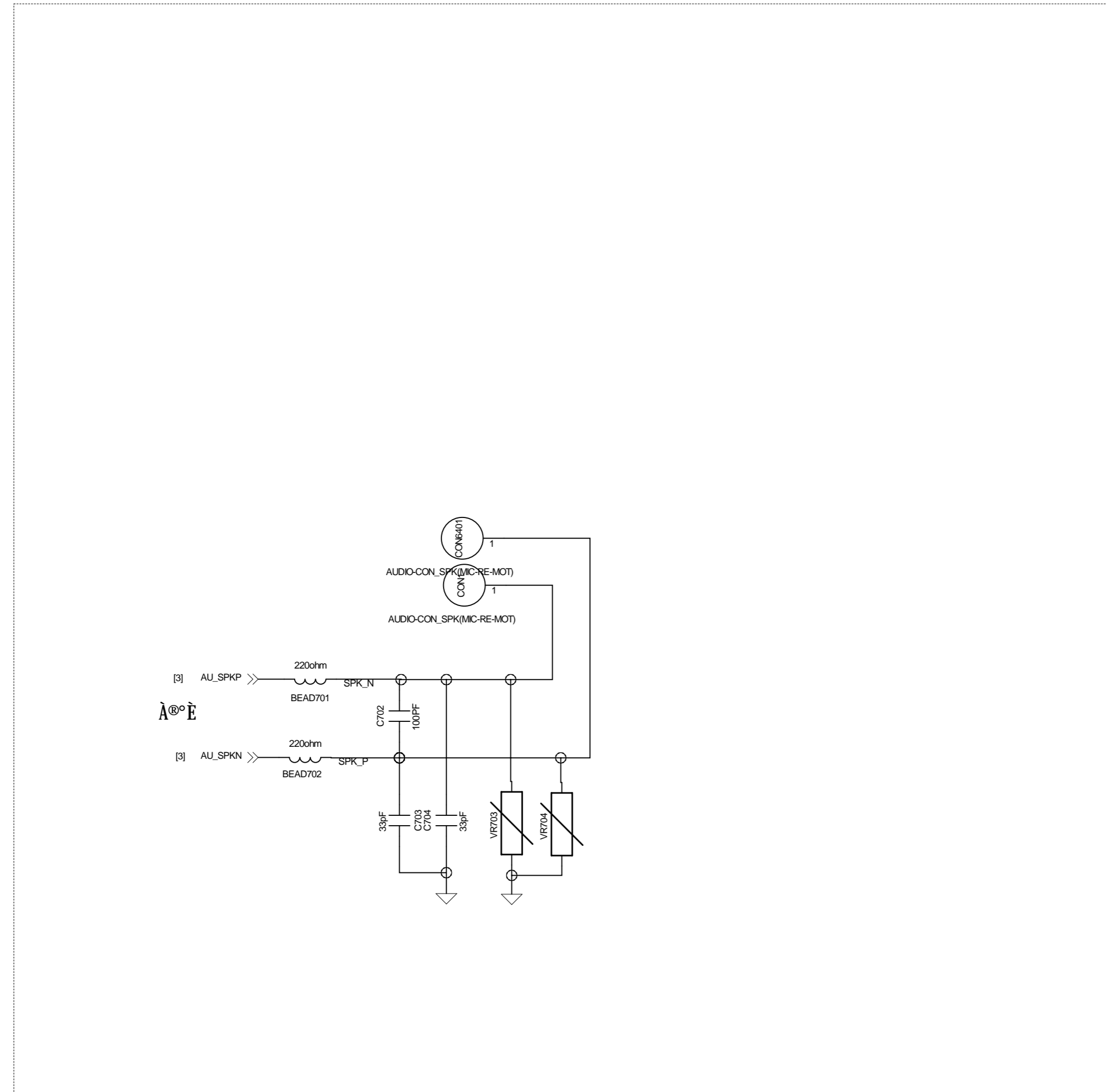



TITLE:	<TITLE>	REV:	<REV>
DOCUMENT NO:	07_USB	SIZE:	A1
DEPARTMENT:	Hardware DEPT.		
COMPANY:			
DESIGNER:	<DESIGNER>	Last Saved Date:	2013-6-26
		SHEET:	8 OF 15



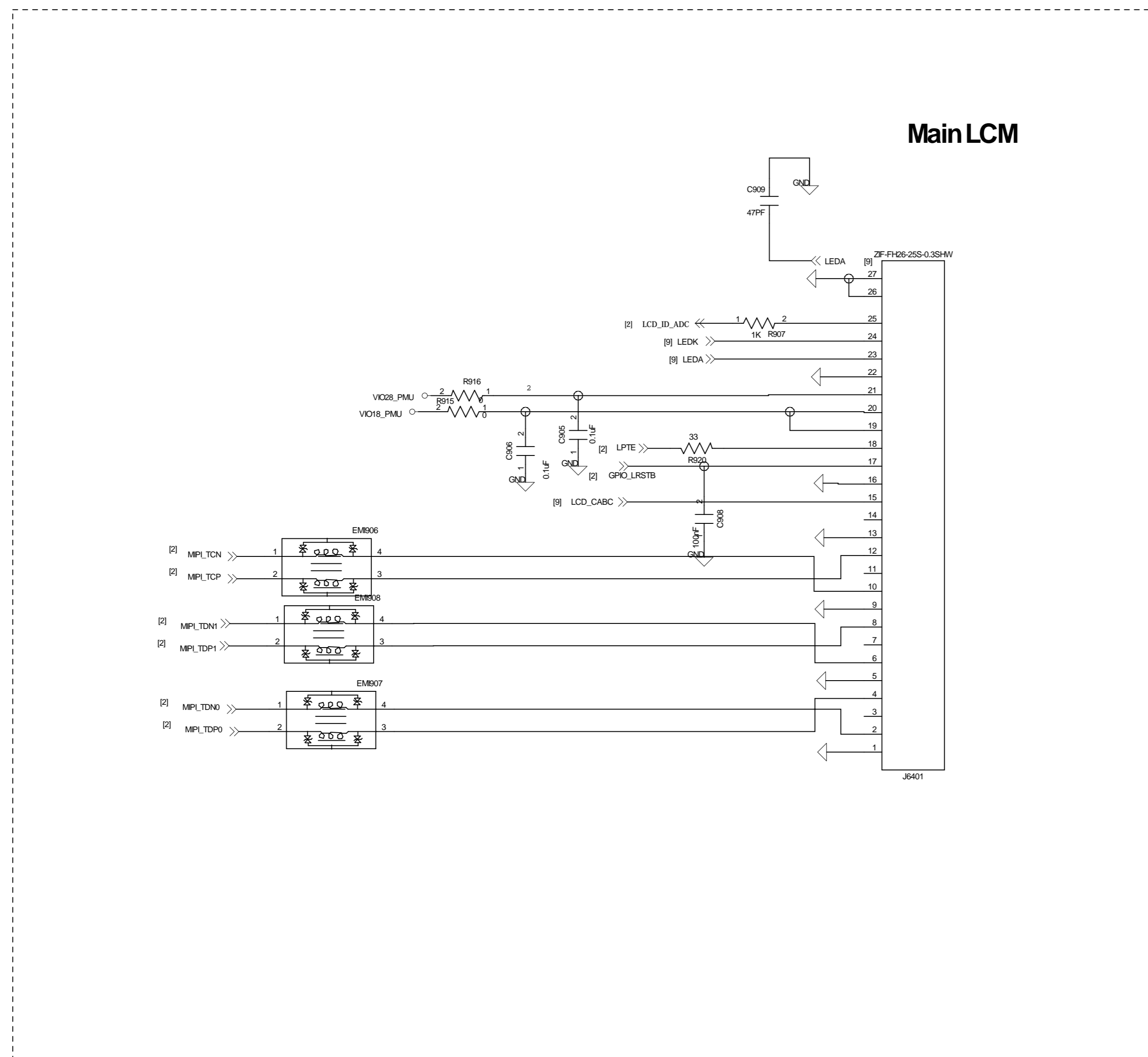
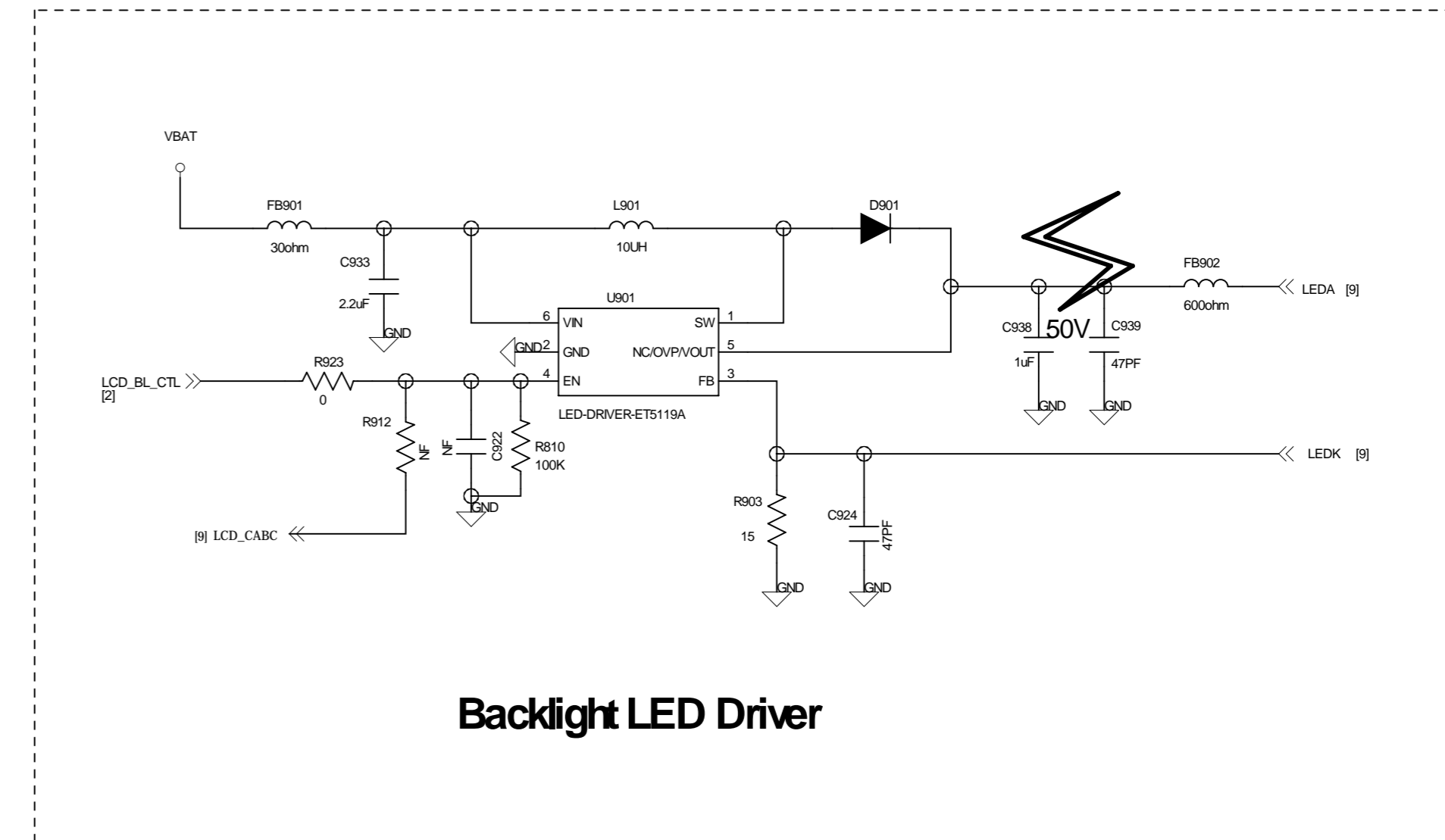
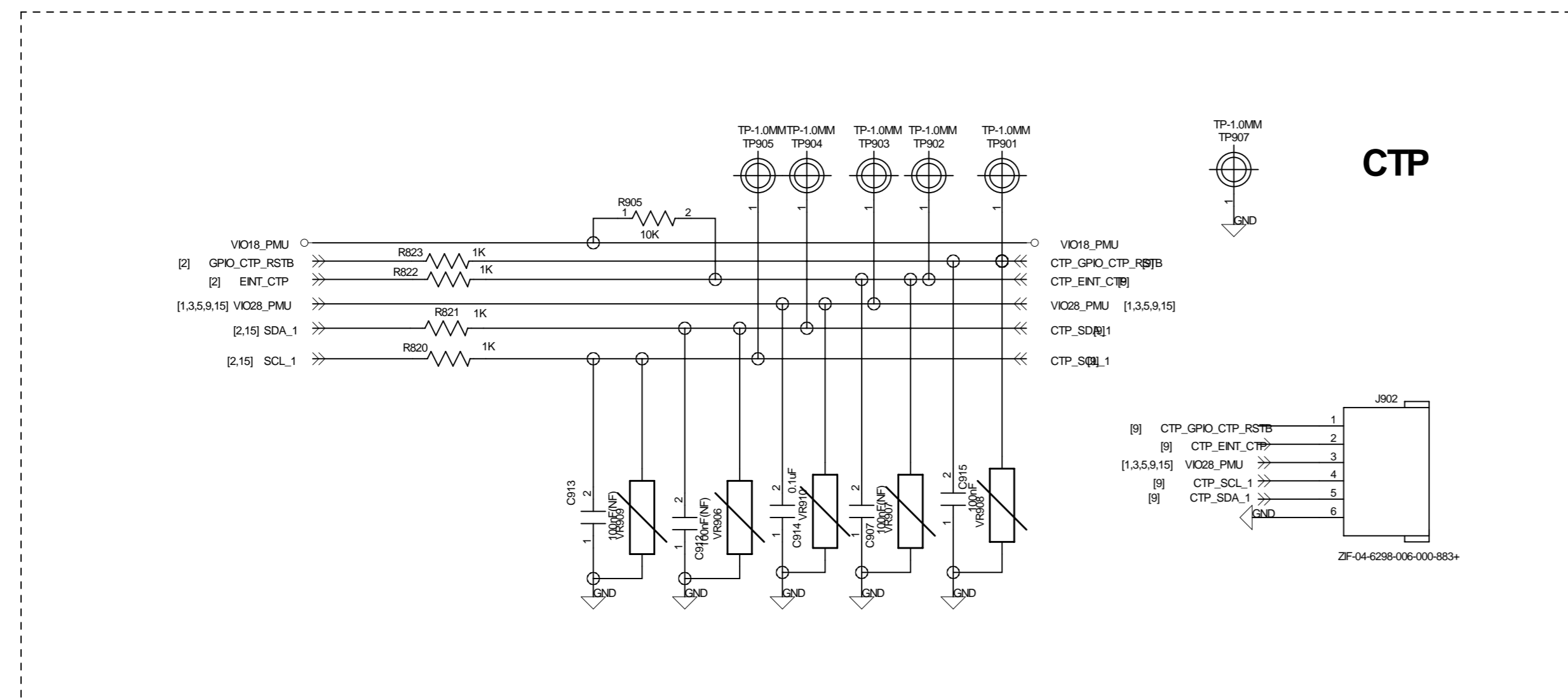

TITLE:	<TITLE>	REV:	<REV>
DOCUMENT NO:	08_LCD_CTP	SIZE:	A1
DEPARTMENT:	Hardware DEPT.		
COMPANY:	<b>WINGTEC</b>		
DESIGNER:	<DESIGNER>	Last Saved Date:	2013-6-26
		SHEET:	9 OF 15

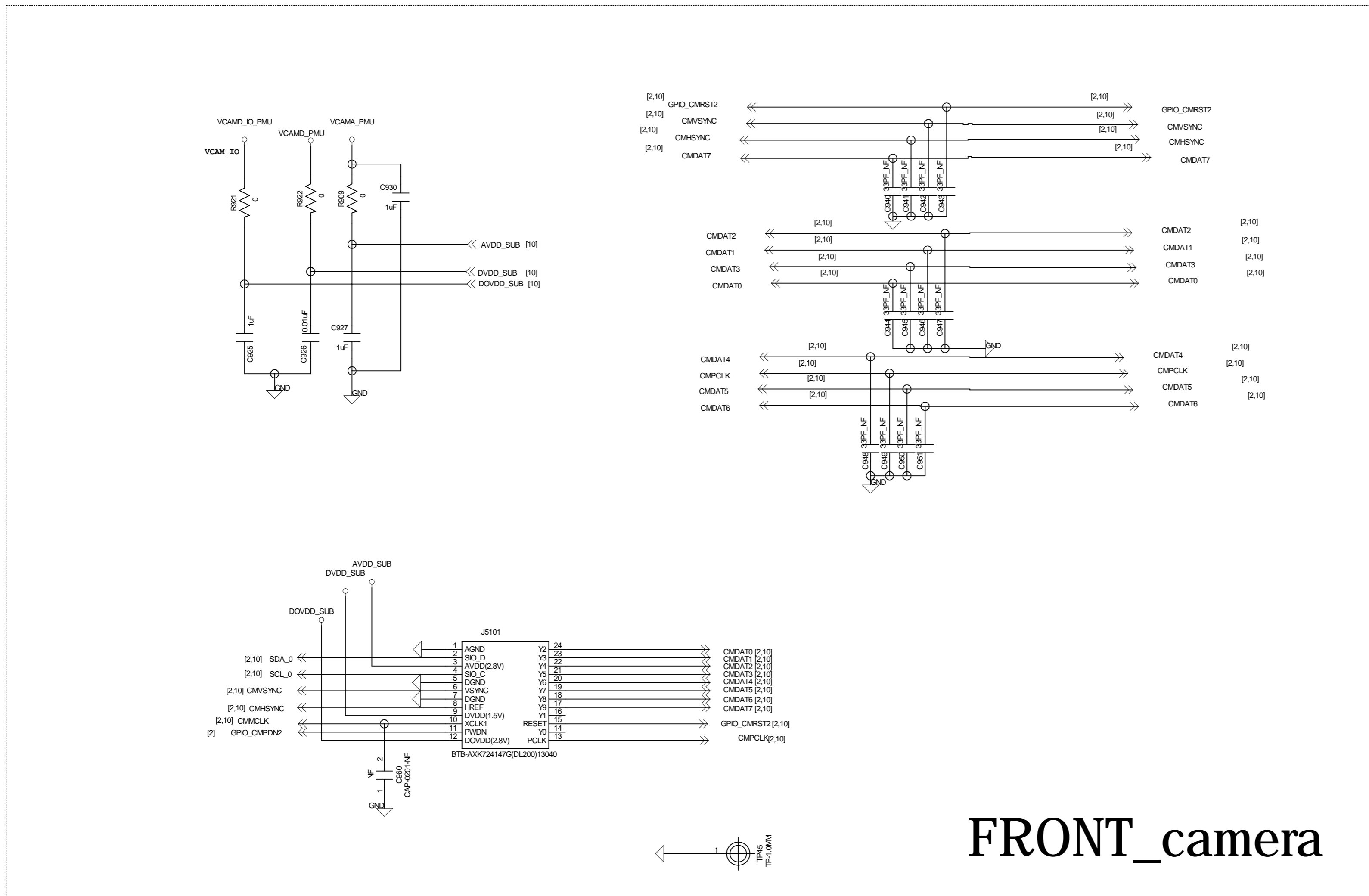

## FRONT\_camera

light sensor 0x90 Write(STK3171)

light sensor 0x46 Write (LTR-558ALS)

Main Camera / Sub Camera share power domain design should double check the voltage level is compatible

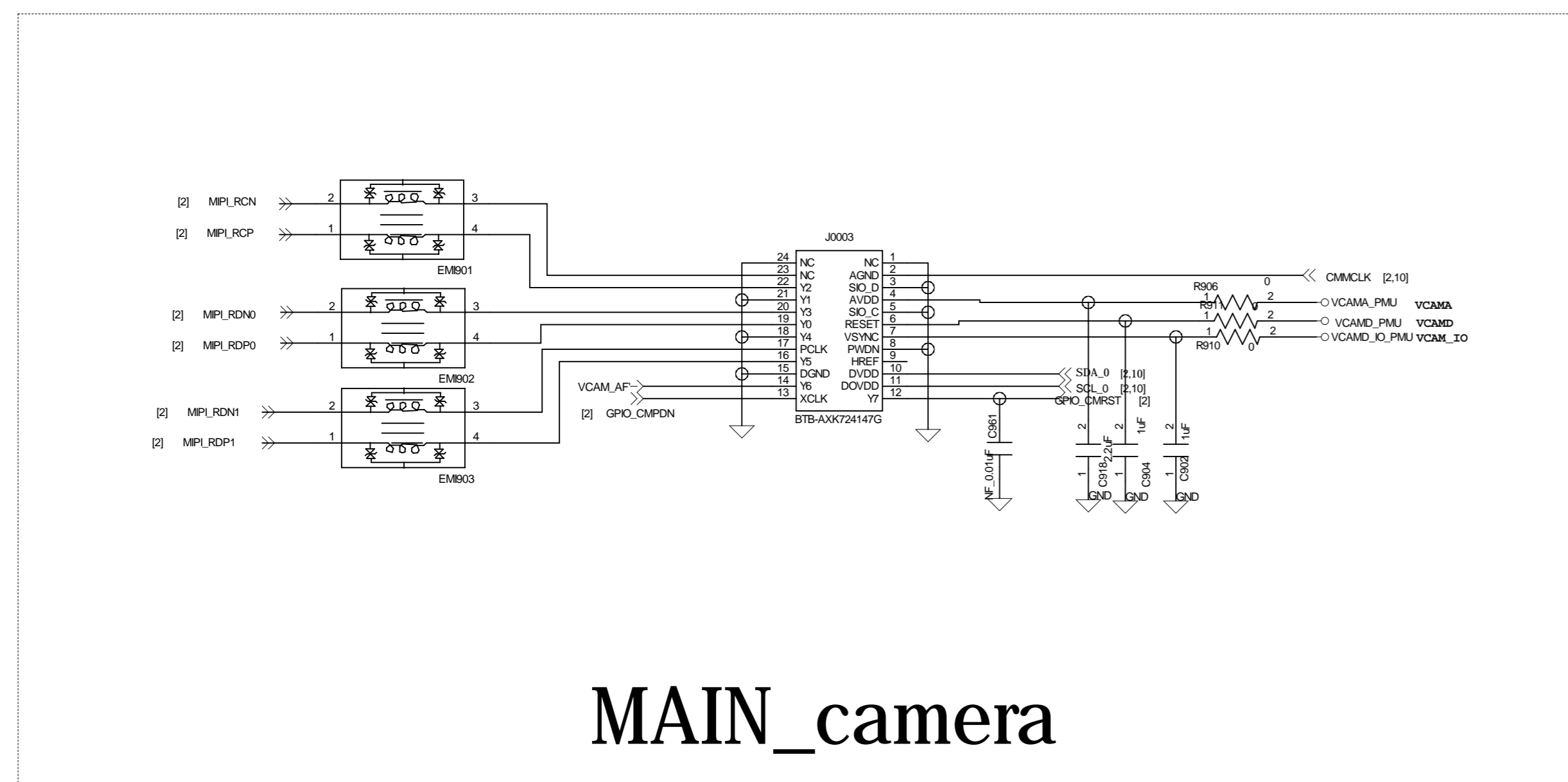

## MAIN\_camera

TITLE:	<TITLE>	REV:	<REV>
DOCUMENT NO:	09_CAMERA	SKED:	A1
DEPARTMENT:	Hardware DEPT.		
COMPANY:			
DESIGNER:	<DESIGNER>	Last Saved Date:	2013-6-26
SHEET:	10	OF	15



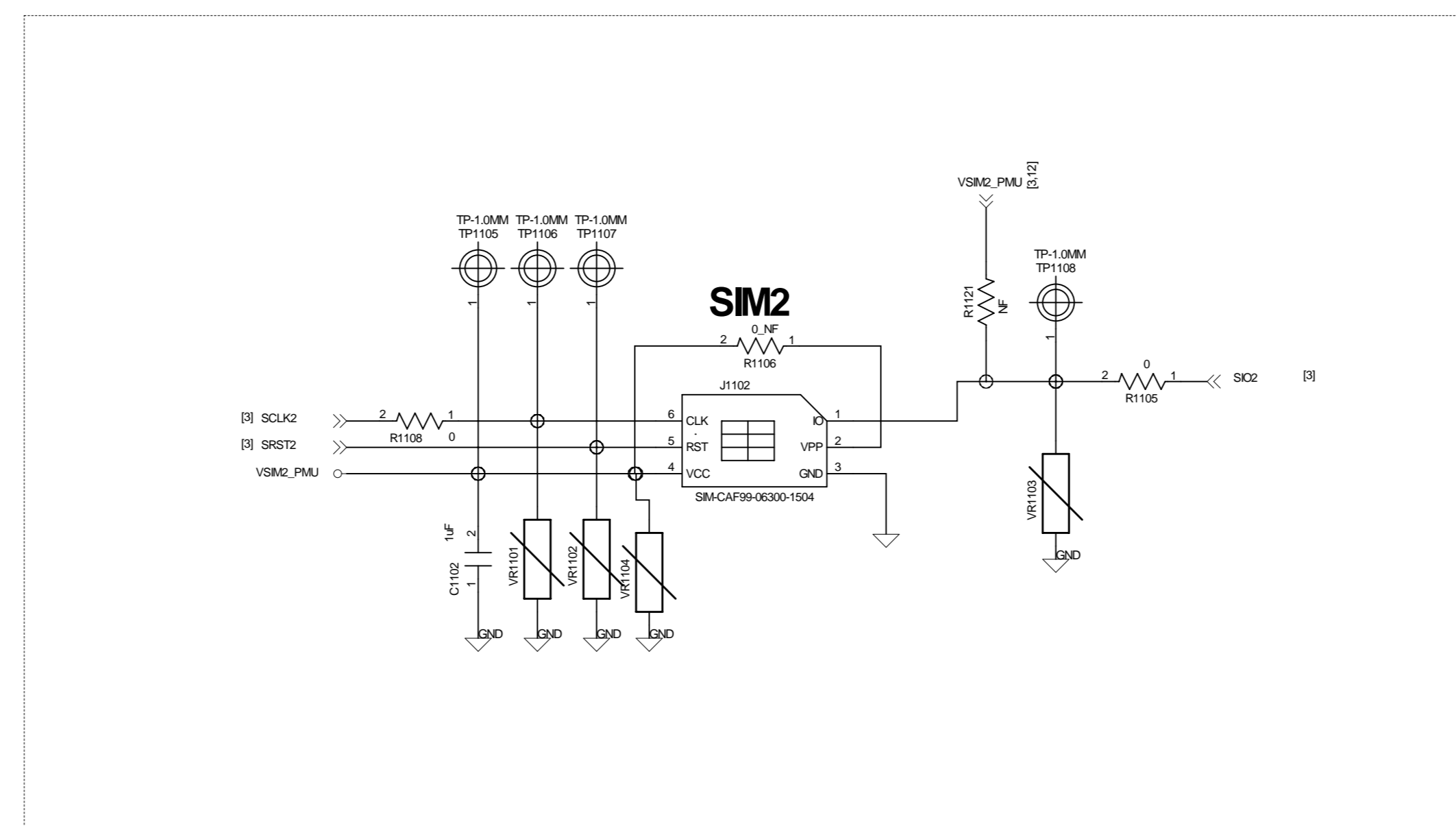
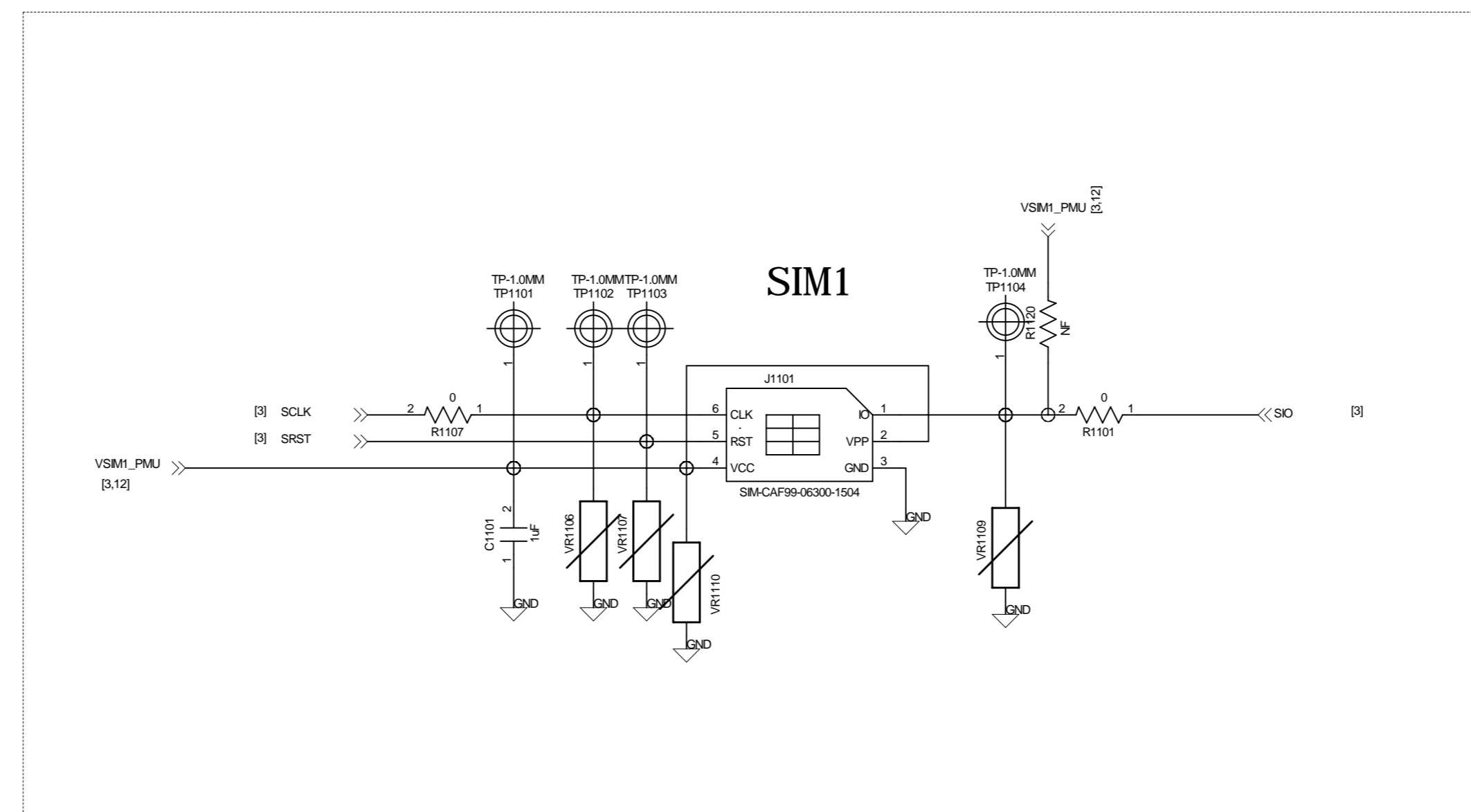

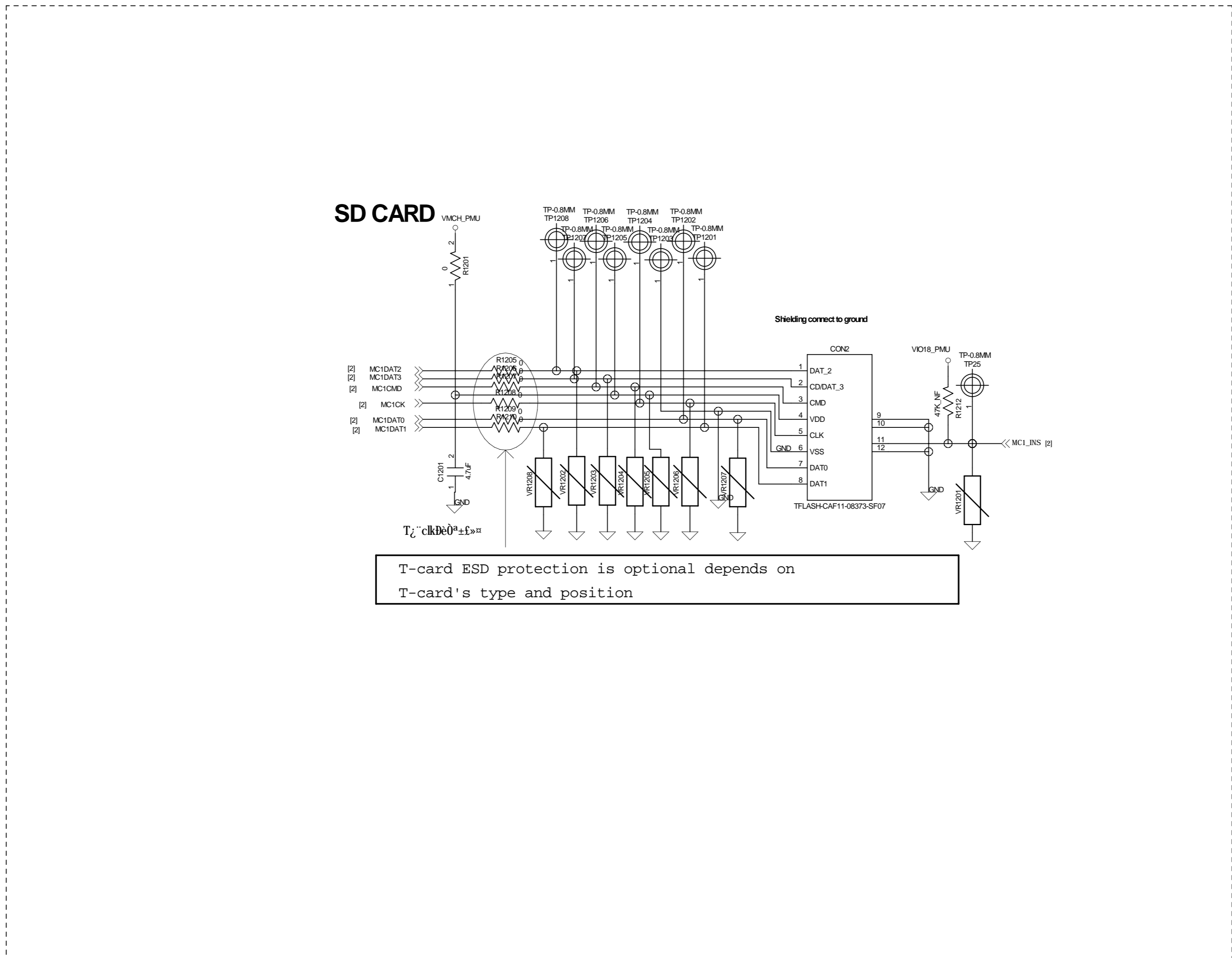

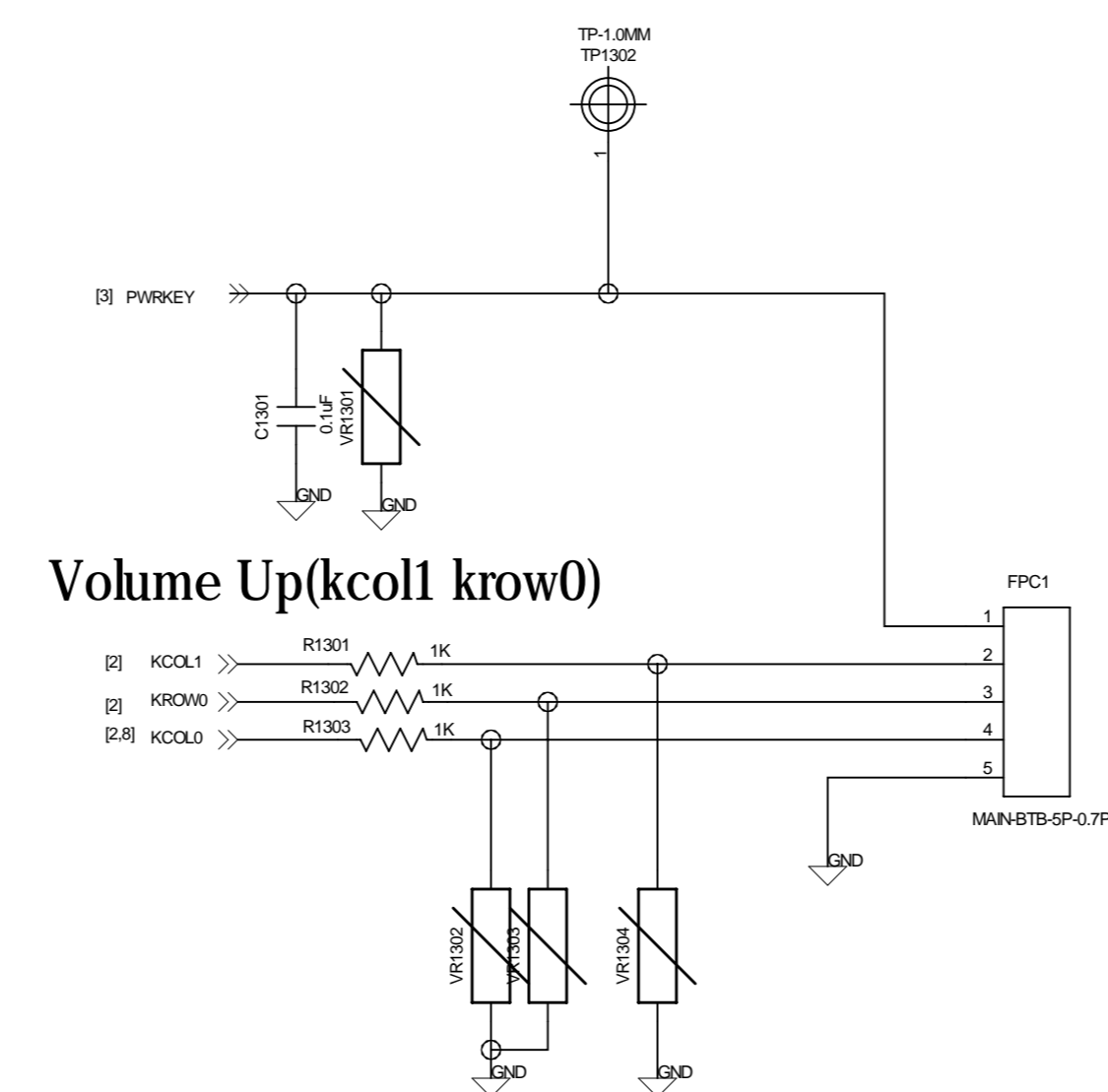

### Power Key

DO NOT put pull-up resistor on PWRKEY

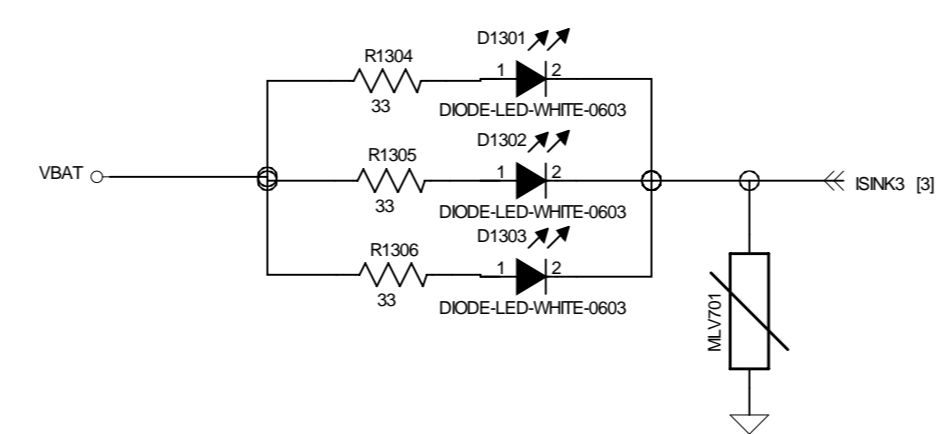

Volume Down(kcol0 krow0) For USB download



TITLE:	<TITLE>	REV:	<REV>
DOCUMENT NO:	13_KEYPAD	SIZE:	A1
DEPARTMENT:	Hardware DEPT.		
COMPANY:			
DESIGNER:	<DESIGNER>	Last Saved Date:	2013-6-26
		SHEET:	14 OF 15

